

# CARPORT VARIATION

Designed Carport which well-harmonized with design and function.

Arched roof shape like a bird wing.  
Wide size variation for various space and lifestyle.  
Strong component and high resistant for wind and snow.  
Easy installation and maintenance.



<p><b>KCR-series</b></p>		<p>Designed carport for various lifestyle with excellent performance.</p> <p>▶ P.3</p> <p><b>SNOW</b> 600 N/m<sup>2</sup> <b>WIND</b> 38 m/s</p>	<p>KCR</p>
<p><b>KDR-series</b></p>		<p>Beautiful arched roof protects your car from wind and rain.</p> <p>▶ P.5</p> <p><b>SNOW</b> 600 N/m<sup>2</sup> <b>WIND</b> 38 m/s</p>	<p>KDR</p>
<p><b>KS/KSS-series</b></p>		<p>Refined simple &amp; basic design.</p> <p>▶ P.9</p> <p><b>SNOW</b> 600 N/m<sup>2</sup> <b>SNOW</b> 900 N/m<sup>2</sup> <b>WIND</b> 38 m/s</p>	<p>KS/KSS</p>
<p><b>MLC-series</b> Standard &amp; Deluxe</p>		<p>Smart &amp; Flat design would set off the simple modern house.</p> <p>▶ P.11</p> <p><b>SNOW</b> 600 N/m<sup>2</sup> <b>WIND</b> 38 m/s</p>	<p>MLC Standard &amp; Deluxe</p>
<p><b>KRB/KRBS-series</b></p>		<p>Higher grade model for wind and snow.</p> <p>▶ P.13</p> <p><b>SNOW</b> 900 N/m<sup>2</sup> <b>SNOW</b> 1500 N/m<sup>2</sup> <b>WIND</b> 38 m/s <b>WIND</b> 42 m/s</p>	<p>KRB/KRBS</p>
<p><b>RSC-series</b> Single &amp; Wide</p>		<p>Front open, a clear view and easy access for parking.</p> <p>▶ P.15</p> <p><b>SNOW</b> 600 N/m<sup>2</sup> <b>WIND</b> 38 m/s</p>	<p>RSC Single &amp; Wide</p>
<p><b>KWC-series</b></p>		<p>Wide projection and cantilever design. 2 different post position available.</p> <p>▶ P.17</p> <p><b>SNOW</b> 600 N/m<sup>2</sup> <b>WIND</b> 38 m/s</p>	<p>KWC</p>
<p><b>CSS-series</b></p>		<p>Snow region model but, Stylish design &amp; Polycarbonate roof panel type.</p> <p>▶ P.19</p> <p><b>SNOW</b> 1500 N/m<sup>2</sup> <b>SNOW</b> 3000 N/m<sup>2</sup> <b>SNOW</b> 4500 N/m<sup>2</sup> <b>WIND</b> 46 m/s</p>	<p>CSS</p>



Designed carport for various lifestyle with excellent performance.

Single Basic

KCR-5127 (SLC)

### M-Connection

Joint type of Single Basic for easy installation



KCR-51 • 2427M (UC)

### Y-Connection

Novel layout



KCR-51 • 2727Y (UC)

### In-Line Connection

Various combination for in-line parking



KCR-5151 • 27W (UC)

### In-Line Short Extension

1.4m short length extension



KCR-5114 • 27E (UC)

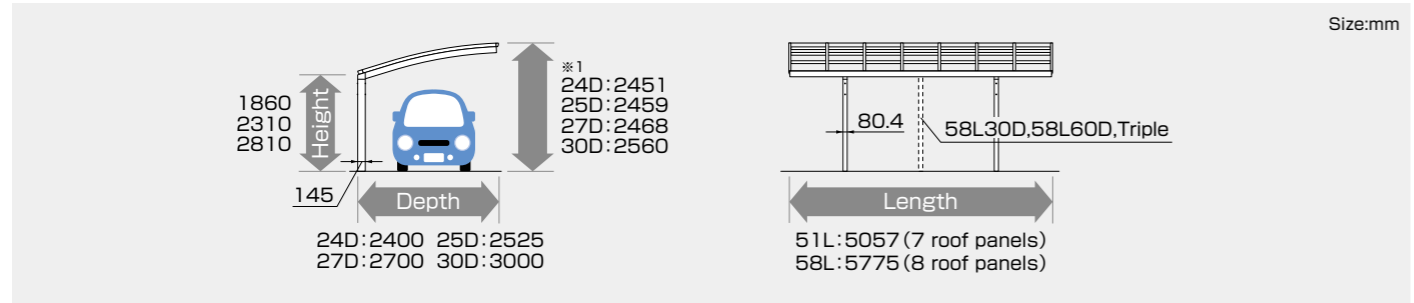

### Wide Beam

Wide open carport with unified beams



KCRW-5154 (UC)

Wind pressure resistance  
**WIND 42**  
m/s

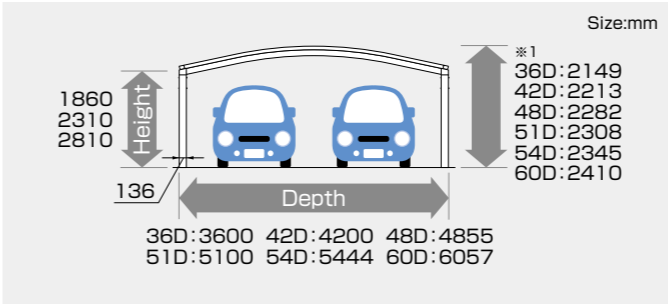

### Wide Beam Single

Unified beams for one vehicle



KCRW-5127 (UC)

Wind pressure resistance  
**WIND 42**  
m/s

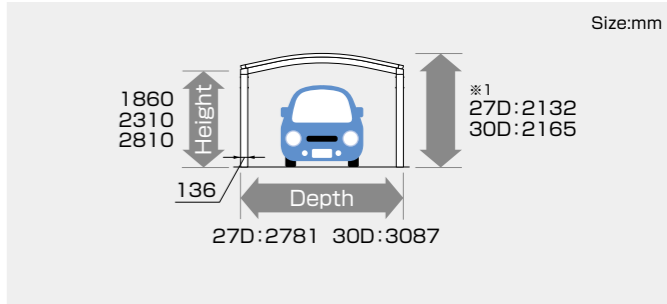

### Wide Beam Triple

Wide open carport for three vehicles



KCRT-5880 (UC)

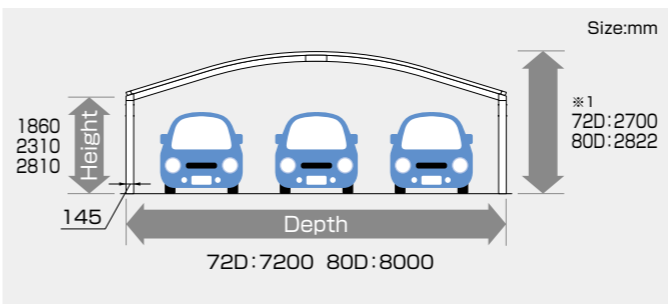

### Mini

Suite for motorcycles and bicycles



KCR-2920 (UC)

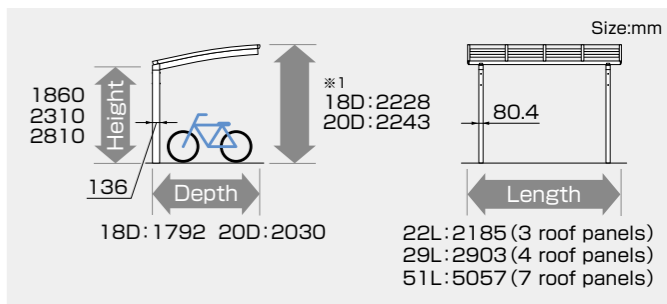

\*1. Overall roof height shows for H:1860 post. Plus 450mm for H:2310 post, plus 950mm for H:2810 post.

### ALUMINIUM COLOR

SLC Sun Silver	UC Urban Gray	BKC Brown
KC Black	BR Bronze	

### STRENGTH

Snow load resistance  
**SNOW 600**  
N/m<sup>2</sup>

Wind pressure resistance  
**WIND 38**  
m/s

### ROOF COLOR

polycarbonate			heat protection	
BR brown smoke	AO blue smoke	SI clear mat	polycarbonate	FRP





Beautiful arched roof protects your car from wind and rain.

Single Basic

KDR-5127 (SLC)



Wide Beam

KDRW-5154 (UC)

Single Basic



KDR-5127 (UC)

M-Connection



KDR-51 • 2427M (UC)

Wide Beam



KDRW-5154 (UC)

Wind pressure resistance  
**WIND**  
42 m/s

Mini



KDR-2920 (UC)

In-Line Connection



KDR-5151 • 27W (UC)

In-Line Short Extension



KDR-5114 • 27E (UC)

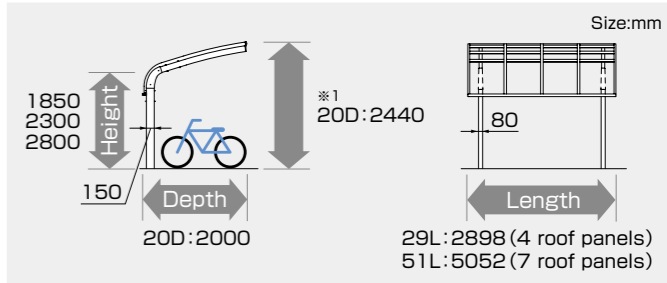
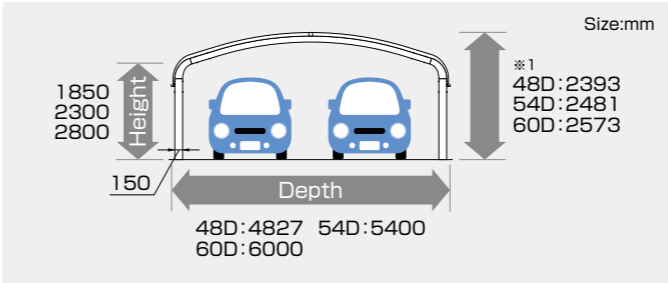

※1. Overall roof height shows for H:1850 post. Plus 450mm for H:2300 post, plus 950mm for H:2800 post.

ALUMINIUM COLOR

- SLC Sun Silver
- UC Urban Gray
- BKC Brown
- KC Black
- BR Bronze

STRENGTH

Snow load resistance  
**SNOW**  
600 N/m<sup>2</sup>

Wind pressure resistance  
**WIND**  
38 m/s

ROOF COLOR

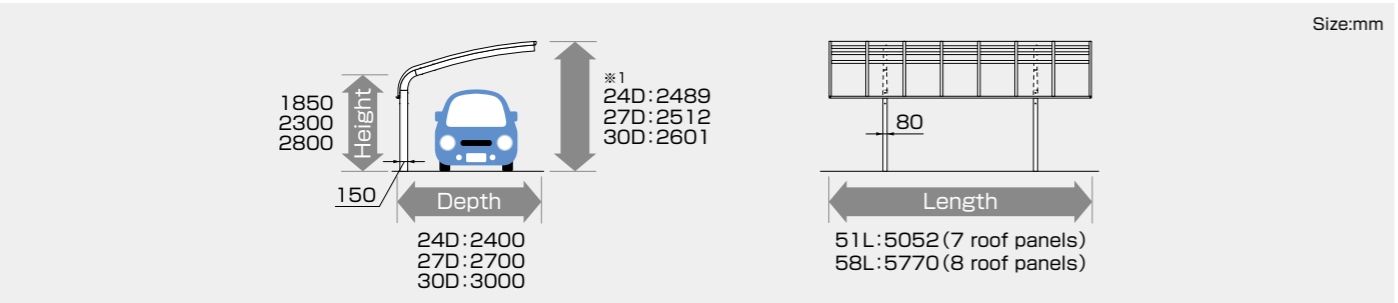
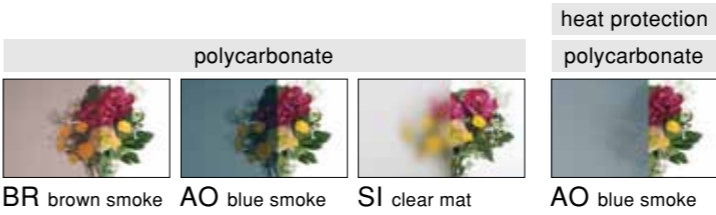

KCR  
KDR  
KS/KSS  
MLC Standard & Deluxe  
KRB/KRBS  
RSC Wide  
KWC  
CSS

## Feature

### ■KCR-series

### ■KDR-series

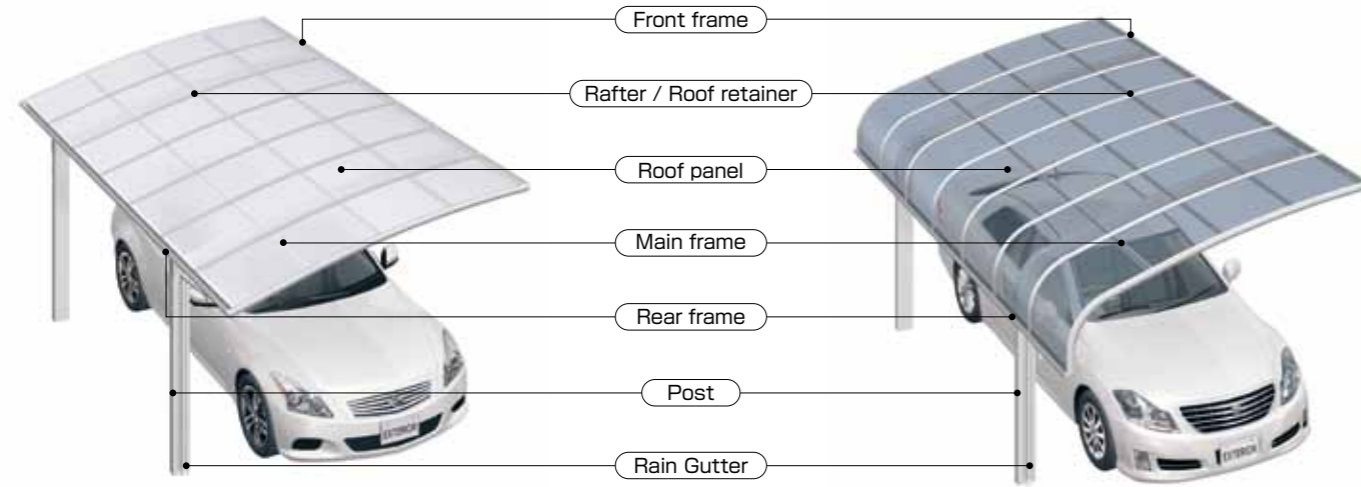

## Color

### 5 colors variations match your multiple home styles.

Enjoy your color coordination from 5 colors variations.



SLC Sun Silver

UC Urban Gray

BKC Brown

KC Black

BR Bronze

## Strength

●Single basic · Wide beam triple

●Wide beam

Vex=38m/s

Vex=42m/s

■Roof retainer · Rafter

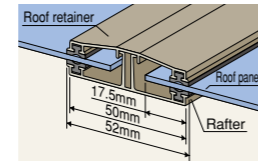

Width of roof retainer and rafter and the panel holding capacity has been improved. The wind resistant performance has been reinforced.

## Effective utilization of the housing site

### Installations to fit the ground conditions are available.

■Trapezium installation

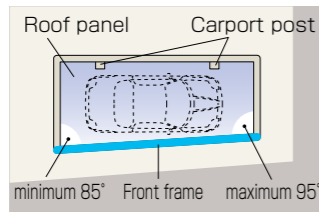

### Option

It is able to install front frame at an angle of 85°~95° to fit the ground shape.

**notes**  
Trapezium installation is available only for single basic installation.

■Flush surface (KCR-series)

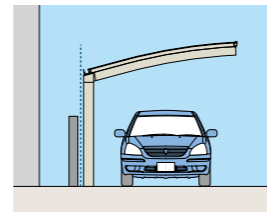

Since the frames do not protrude from the post, it is possible to locate the carport close to the border of the parking space.

## Post Type

### Long post type fits for Minivan or SUV with roof carrier.

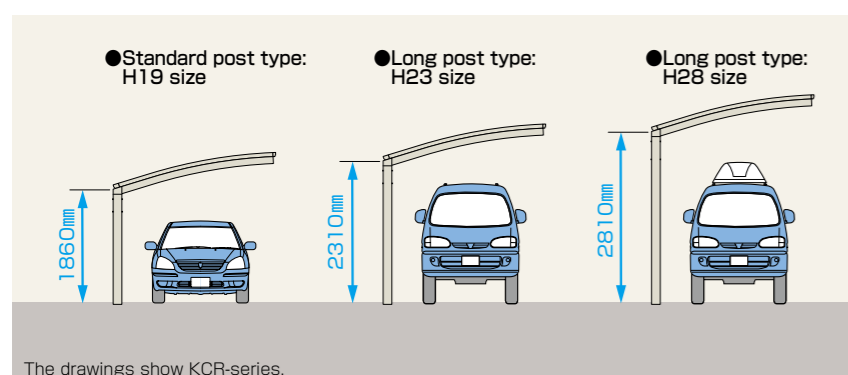

The drawings show KCR-series.

Standard post type H19, and 2 different long post types H23, H28 are available.

## Drain Elbow

### Drain elbow for easy maintenance.



Using drain elbow which can remove dust accumulated in the rain makes its maintenance easier.

## Locking Bolt

### Nylon can prevent bolt loosening.

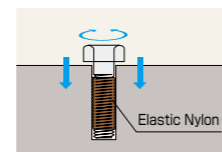

Elastic Nylon coated screws heighten an effect of locking and sealing.

## Option

### Side Panel

■KCR-series

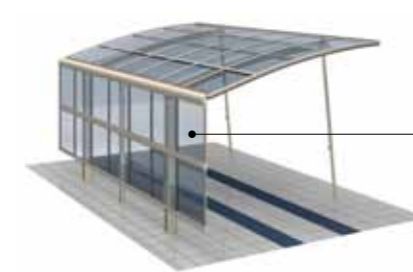

**notes-1** Not available to set it up on H28 post (H=2.8m).  
**notes-2** Required the support post and roof panel support when set up H08 or higher side panel.

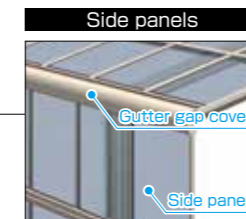

Gutter gap cover include in the side panel sets.

■KDR-series

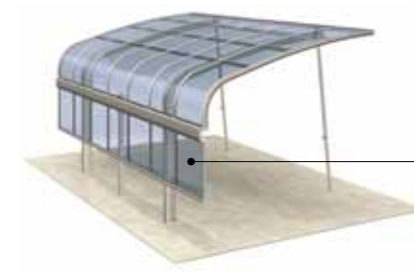

**notes-1** Not available to set it up on H28 post (H=2.8m).  
**notes-2** Required the support post and roof panel support when set up H08 or higher side panel.

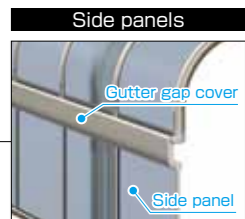

Gutter gap cover include in the side panel sets.

Wind pressure resistance  
**WIND**  
38 m/s  
SINGLE

Wind pressure resistance  
**WIND**  
34 m/s  
WIDE · TRIPLE

## Removable Support Post

### Upgrading for the carport's wind strength

Support Post Holder



Flash surface holder on the ground

Adjustable



Removal system and compact size

Smart Holding

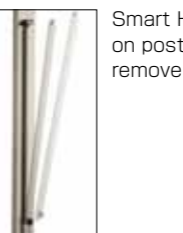

Smart Holdings on post when remove it

When installing its support post and roof panel support together, the wind strength of the carport comes higher at Vex=42m/s than standard 38m/s.

**notes**  
Cantilever type is recommended to install support post preparing the sudden strong wind, and please make sure to use support post when the strong winds occur.

## Hurricane Protection (KCR-series)

### Controlling the roof fall off against hurricane

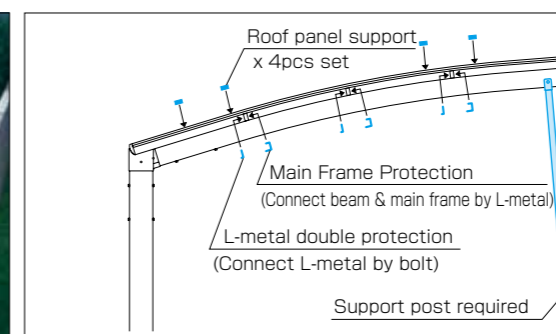

Hurricane Protection is available after standard installation.

**notes**  
Removable support post required on hurricane support program.

●Diagram of the Hurricane Protection

Single basic	Wide beam	Triple	Mini
●	×	×	●

## Roof Panel Support (KCR-series)

Wind pressure resistance  
**WIND**  
42 m/s

### Upgrading for the panel holding strength

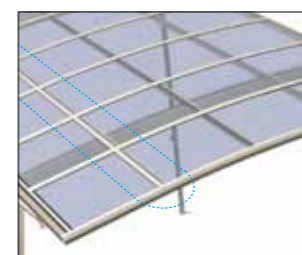

Roof panel support that reinforce the roof panels against strong wind ensure the safety of the carport.

**notes**  
Required the support post.

●Diagram of the roof panel support

Single basic	Wide beam	Triple	Mini
●	—	●	●

## Protect Cushion



The picture shows 2pcs setting.

The rubber cushion protects hitting door and post while getting on/off the car. Installation screws are invisible because of double layer profile.

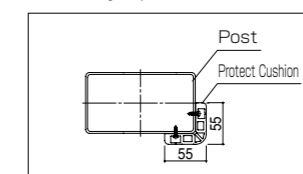

## Aluminium Rain Gutter

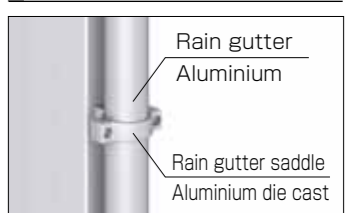

Aluminium rain gutter and saddle.

## Clothes Hanger

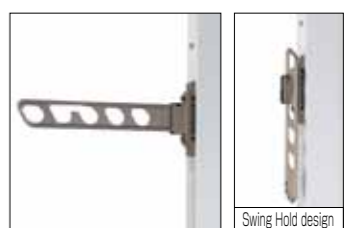

Upper 45°, Horizontal, Lower 45°



Refined simple & basic design

Single Basic

KS-4324 (SLC)



Up-Grade Snow Load model (30cm) with 3 posts stand.

Single Basic

KSS-5027 (SLC)

M-Connection

Y-Connection

In-Line Connection



KS-51 · 2727M (UC)



KS-51 · 2727Y (UC)



KS-5151 · 27W (UC)

M-Connection

Y-Connection

In-Line Connection



KSS-51 · 2727M (UC)



KSS-51 · 2727Y (UC)



KSS-5151 · 27W (UC)

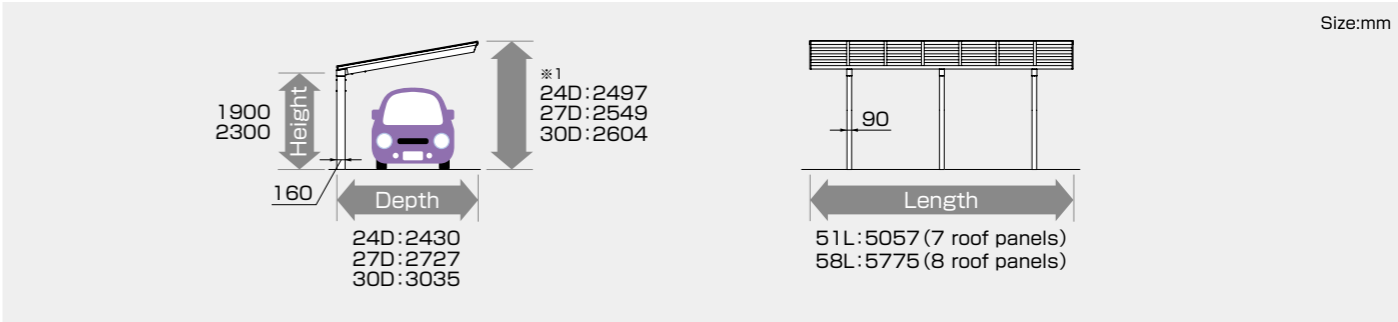
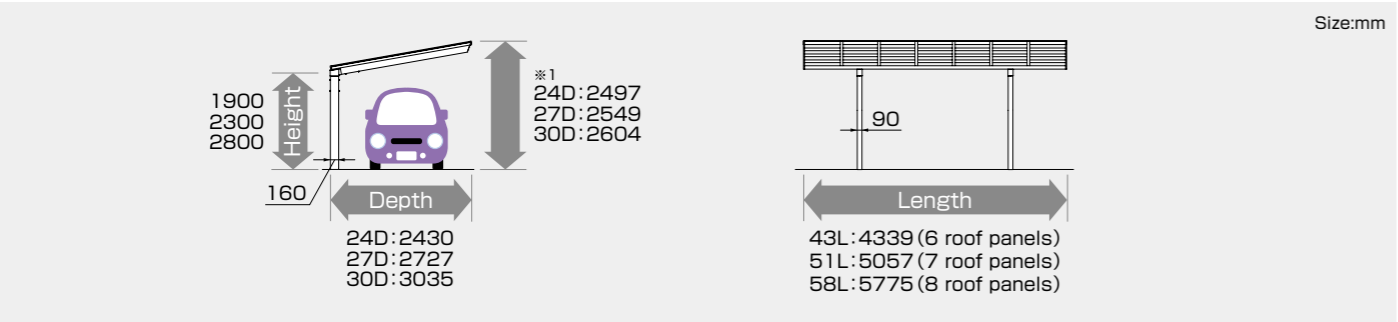

ALUMINIUM COLOR

SLC Sun Silver	UC Urban Gray	BKC Brown
-------------------	------------------	--------------

ROOF COLOR

polycarbonate	heat protection polycarbonate	heat absorb polycarbonate
AO blue smoke	AO blue smoke	SI clear mat

● Cost-effective 2 Posts type

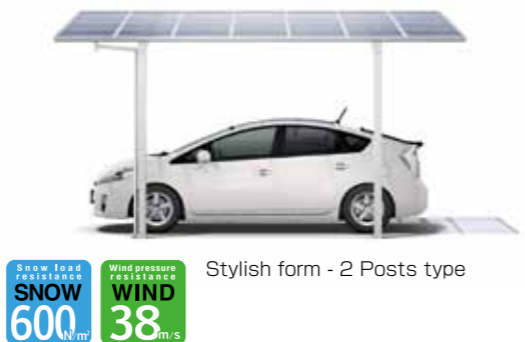

Stylish form - 2 Posts type  
 SNOW 600 N/m<sup>2</sup> WIND 38 m/s

● High-intensity 3 Posts type



Strong & Tough, Flagship - 3 Posts type  
 SNOW 900 N/m<sup>2</sup> WIND 38 m/s

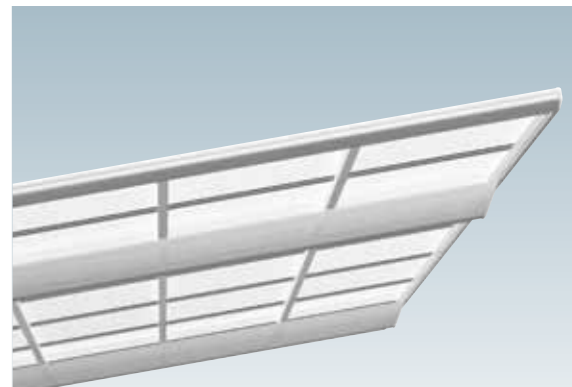



Smart & Flat design would set off the simple modern house.

Single Basic

MLC-5127 (UC)



Wooden lamination frame directs a high-sense and stylish.

Single Basic

MLC-L5127 (CML)



M-Connection

MLC-51-2727M (KC)



In-Line Connection

MLC-5151-27W (SLC)



Wide Beam

MLC-5154 (SLC)



Reverse Incline Roof

MLC-RL5127 (SLC)



In-Line Short Extension

MLC-L5114-27E (TPL)



Mini

MLC-L5121 (CML)

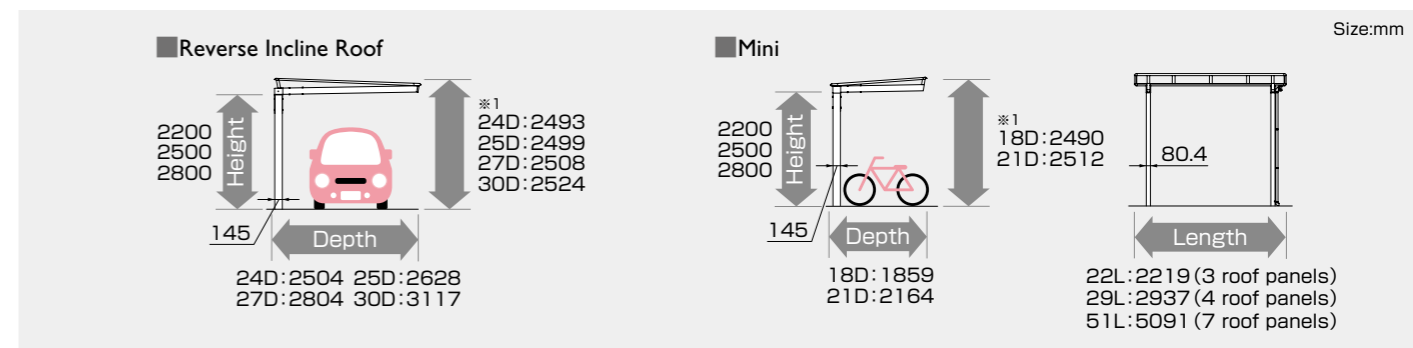
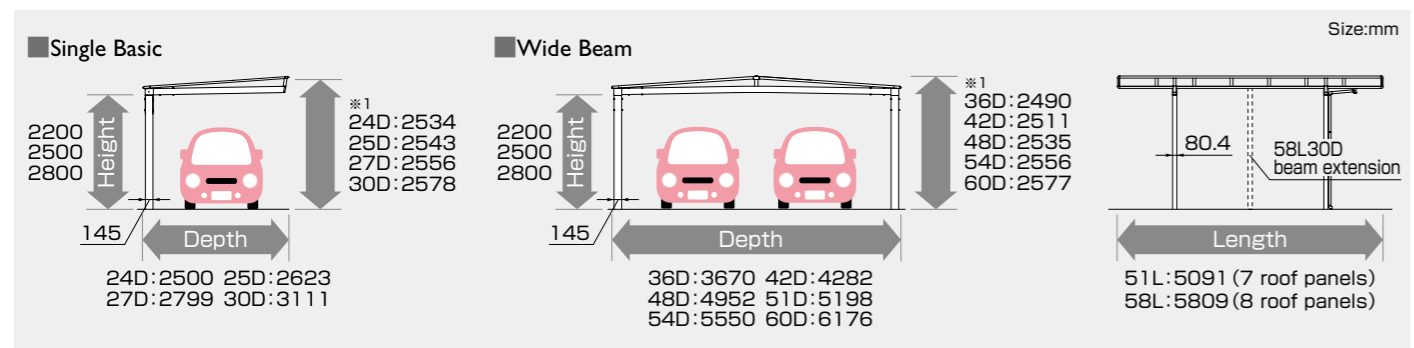

※1. Overall roof height shows for H:2200 post. Plus 300mm for H:2500 post, plus 600mm for H:2800 post.

**COLOR**

MLC Standard

aluminium type			
SLC Sun Silver	UC Urban Gray	BKC Brown	KC Black

MLC Deluxe

laminate type		aluminium type	
TP Trad Pine	SLC Sun Silver	SLC Sun Silver	UC Urban Gray
	CM Choco Maple		
	SLC Sun Silver		
TPL	CML	KC Black	

You can choose the frame style, wooden lamination frame or aluminium frame ( the same color as the carport body ). Left color is frame color, and right color is base color ( body color ).

**ROOF COLOR**

polycarbonate			heat protection		
BR brown smoke	AO blue smoke	SI clear mat	polycarbonate	FRP	FRP DR-type
			AO blue smoke	SI clear mat	SI clear mat

**STRENGTH**

Snow load resistance: SNOW 600 N/m<sup>2</sup>

Wind pressure resistance: WIND 38 m/s

KCR  
KDR  
KS/KSS  
MLC Standard & Deluxe  
KRB/KRBS  
RSC Wide  
KWC  
CSS

Higher grade model for wind and snow.

Highest performance model with 3 posts.

Single Basic

KRB-5027 (UC)

Single Basic

KRBS-5027 (UC)

In-Line Connection

M-Connection

Wide Beam



In-Line Connection

M-Connection

Wide Beam

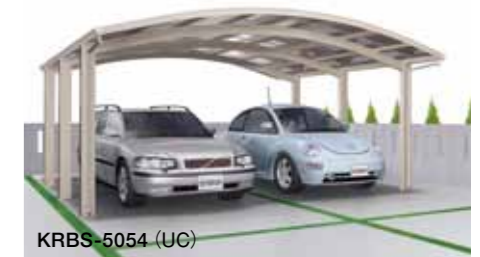

Single Basic

Wide Beam

Size:mm

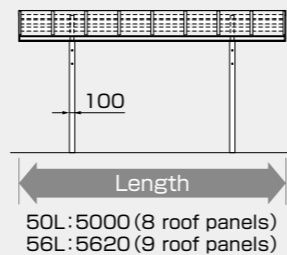
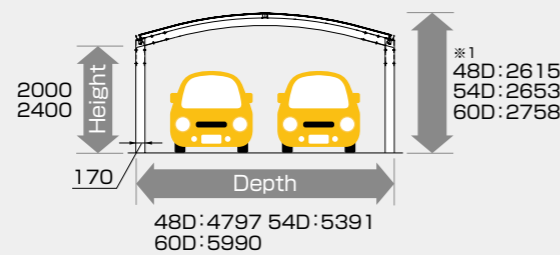
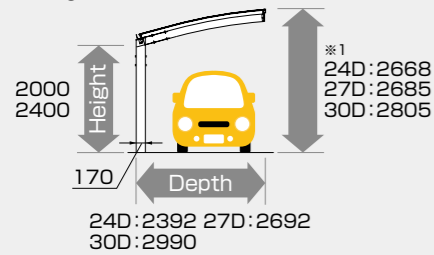

Single Basic

Wide Beam

Size:mm

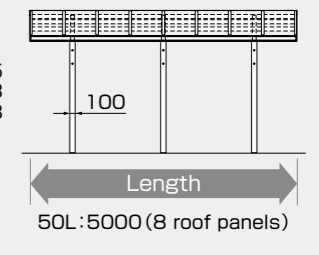
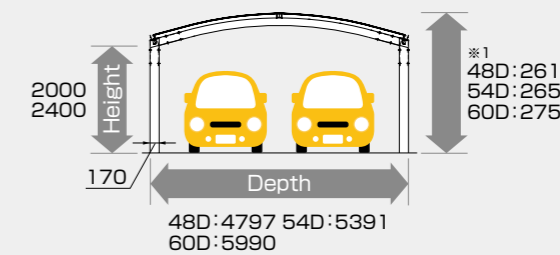
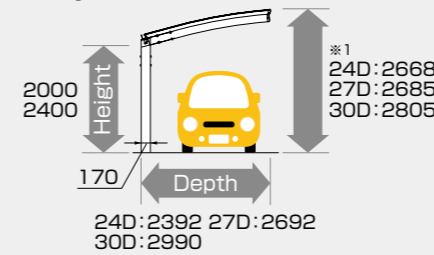

※1. Overall roof height shows for H:2000 post. Plus 400mm for H:2400 post.

※1. Overall roof height shows for H:2000 post. Plus 400mm for H:2400 post.

ALUMINIUM COLOR



ROOF COLOR

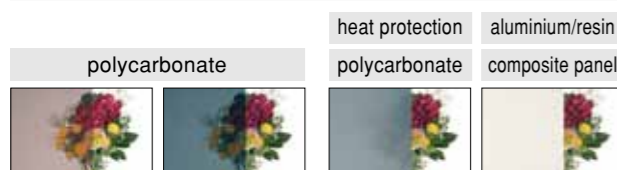

● Cost-effective 2 Posts type



Stylish form - 2 Posts type  
 SNOW 900 N/m<sup>2</sup> WIND 38 m/s

● High-intensity 3 Posts type



Strong & Tough, Flagship - 3 Posts type  
 SNOW 1500 N/m<sup>2</sup> WIND 42 m/s

Post Design

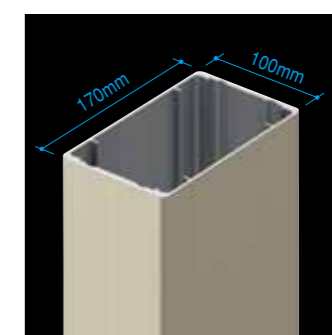

High-intensity & High-efficiency post design.



Single Basic

RSC-5027 (TPL)



Wide

RSC-5054 (SLC)

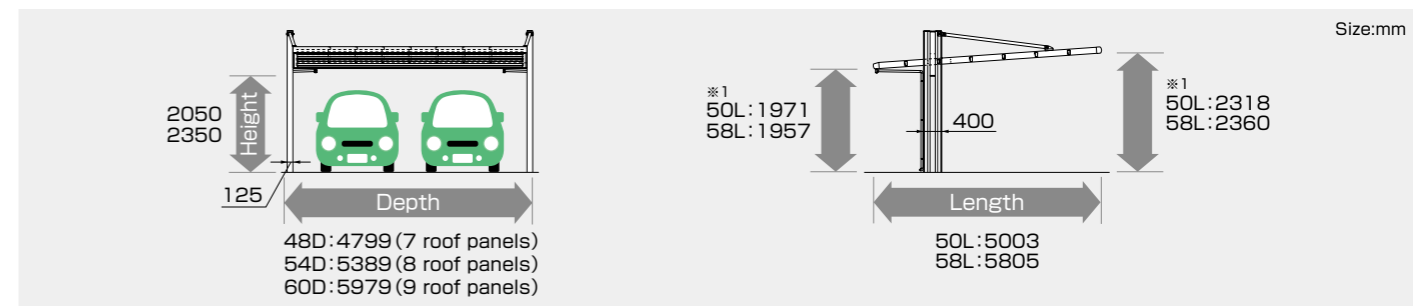
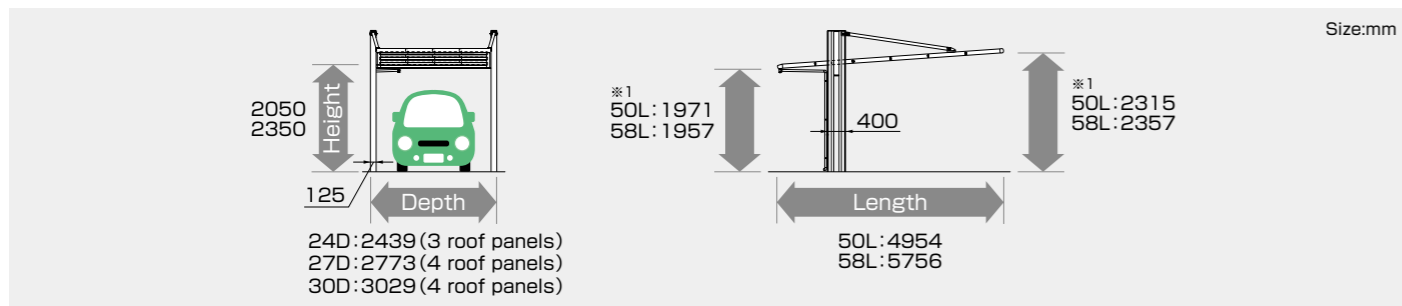

※1. Overall roof height shows for H:2050 post. Plus 300mm for H:2350 post.



Depth Connection

RSC-50-2427M (UC)



COLOR

aluminium type				laminare type					
SLC	UC	TP	SLC	CM	SLC	TP	UC	CM	UC
Sun Silver	Urban Gray	Trad Pine	Sun Silver	Choco Maple	Sun Silver	Trad Pine	Urban Gray	Choco Maple	Urban Gray
TPL			CML			TPU		CMU	

ROOF COLOR

heat protection			
polycarbonate	polycarbonate	FRP	FRP DR-type
SI clear mat	AO blue smoke	SI clear mat	SI clear mat

STRENGTH

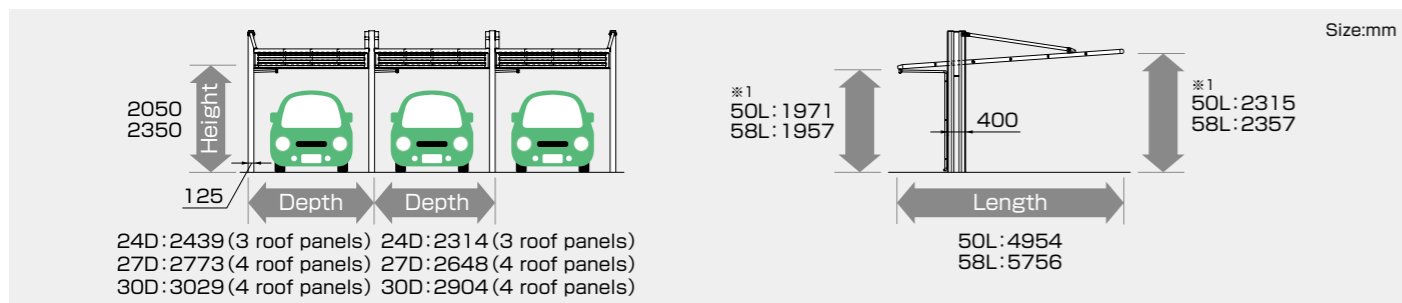

KCR  
KDR  
KSKSS  
MLC Standard & Deluxe  
KRB/KRBS  
RSC Single & Wide  
KWC  
CSS





Wide projection and cantilever design.  
2 different post position available.

Wide

KWC-5154 (TPL)



Wide

KWC-5954 (SLC)

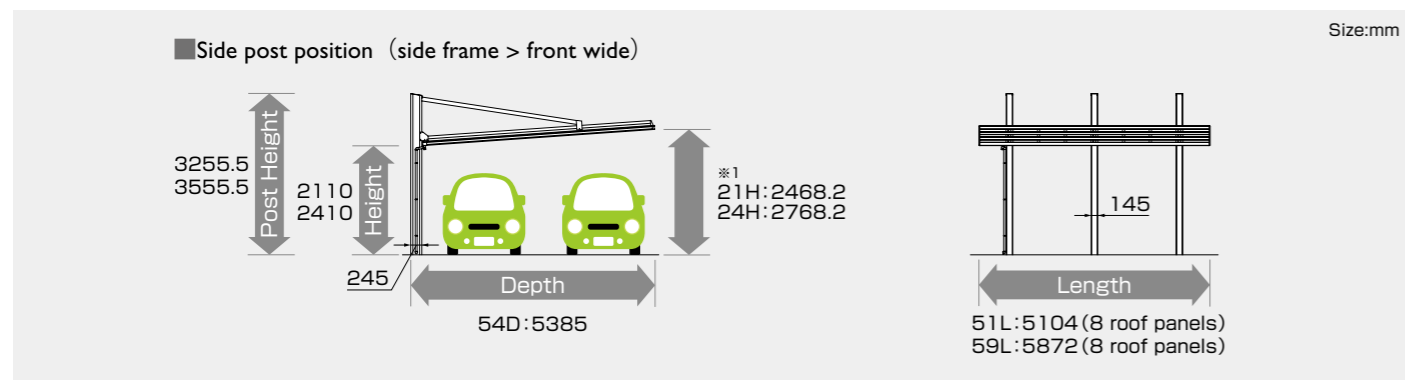

※1. Overall roof height shows for H:2110 post. Plus 300mm for H:2410 post.

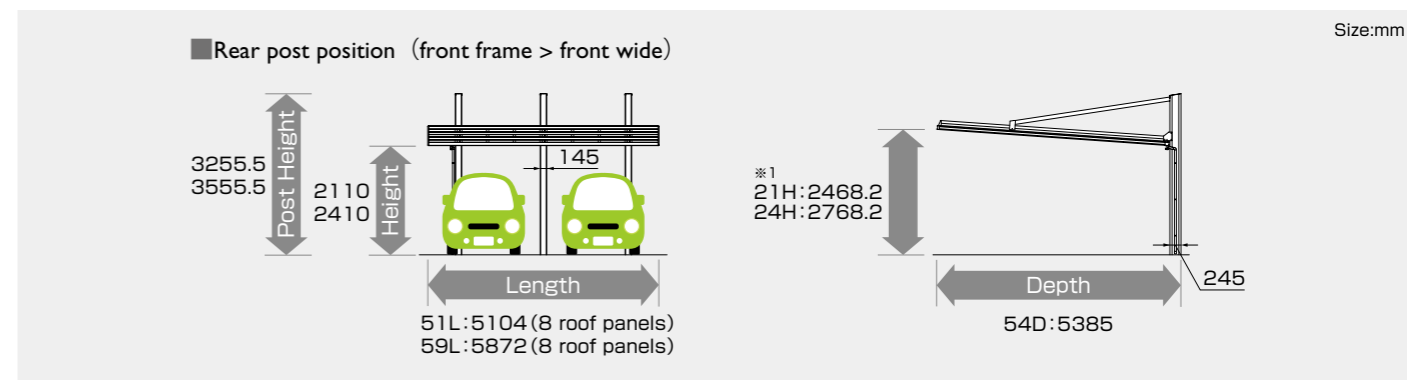

※1. Overall roof height shows for H:2110 post. Plus 300mm for H:2410 post.

COLOR

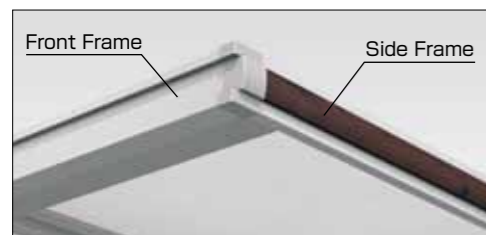

aluminium type		laminate type	
SLC Sun Silver	UC Urban Gray	TP Trad Pine	UC Urban Gray
		TPL	TPU

ROOF COLOR

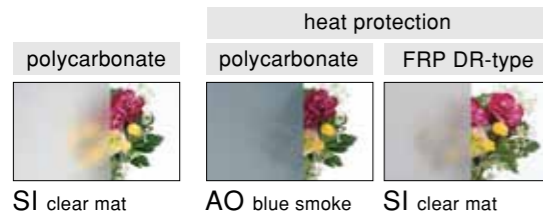

SI clear mat AO blue smoke SI clear mat

STRENGTH



SIDE POST POSITION (SIDE FRAME > FRONT WIDE)

Unified arm and side frames in a round shape. Emphasize the design impact from the side frame view.

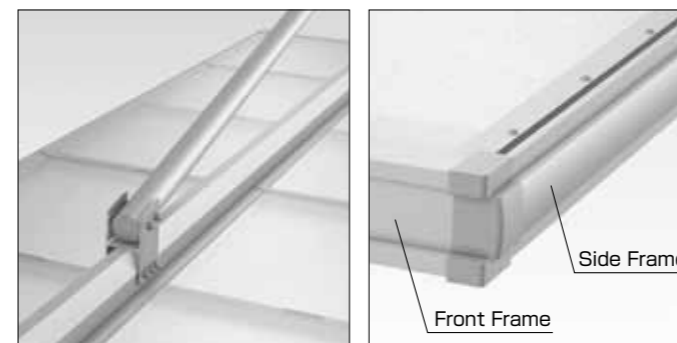

REAR POST POSITION (FRONT FRAME > FRONT WIDE)

Front & Rear frame emphasize the FLAT LINE design and suit & fit for the house design.

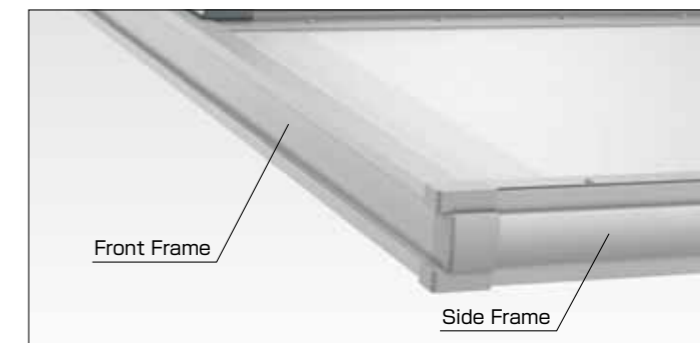



Snow region model but, Stylish design & Polycarbonate roof panel type.

Wide Beam

CSS-5154 (SLC)



ALUMINIUM COLOR



STRENGTH



ROOF COLOR

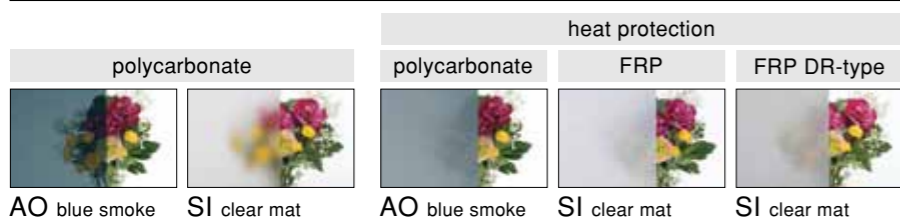

Lineup Table & Diagram

Type			50cm snow 1500N/m <sup>2</sup>	100cm snow 3000N/m <sup>2</sup>	150cm snow 4500N/m <sup>2</sup>
Single Basic	One vehicle	depth: 31	4 posts 	6 posts 	8 posts 
		depth: 54	4 posts 	6 posts 	8 posts 
Wide Beam	Two vehicles	depth: 54	4 posts 	6 posts 	8 posts 
		depth: 61	4 posts 	6 posts 	8 posts 
Wide Beam Triple	Three vehicles	depth: 80	6 posts 	8 posts 	not available
In-line connection	Two vehicles	depth: 31	8 posts 	12 posts 	16 posts 

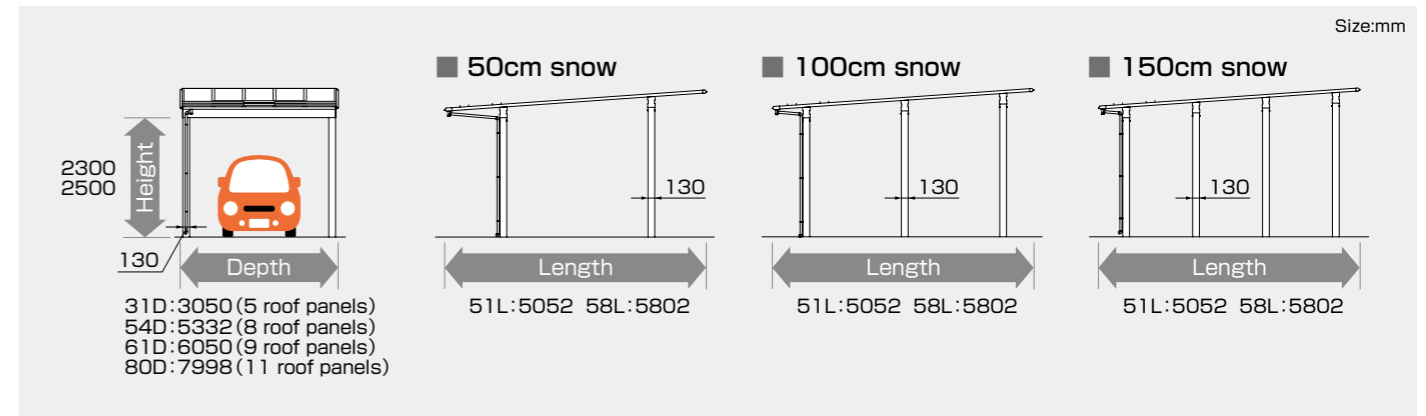

KCR  
KDR  
KS/KSS  
MLC Standard & Deluxe  
KRB/KRBS  
RSC Wide  
KWC  
CSS

# Heat Protection Polycarbonate



AO blue smoke

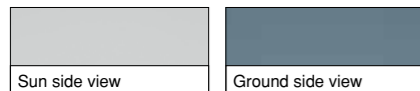

When looking from the sun side, the surface reflects in sunlight, therefore the color of the panel looks different from the ground side view.



**Cuts out 75% of heat rays**

Almost all harmful ultraviolet rays (UV) can be cut out. The roof protects car paintwork from fading and car seats from discoloring.

The temperature in sun-heated cars can rise to 61.6°C. Heat protection polycarbonate carports protect your cars from the summer heat.

**CAR INSIDE = 17°C**

Polycarbonate roof protects your car from heat waves and restricts temperature rise in the car.

■ Effect of polycarbonate roof against heat wave (our test result)

Exposed to the sun	Under general polycarbonate roof	Under heat protection polycarbonate roof
61.6°C	50.3°C	43.9°C

The above values are actual values measured by us and not guaranteed values for the products.

**Approx. 250 times stronger than glass**

Polycarbonate sheet has impact resistance approx. 250 times higher than glass.

It can even withstand being hit with a hammer. The polycarbonate roof can protect your car from bad weather conditions such as hail. In addition, since it does not harden, it is suitable for use in cold climates.

Fig. 1: Wavelength of sun's rays

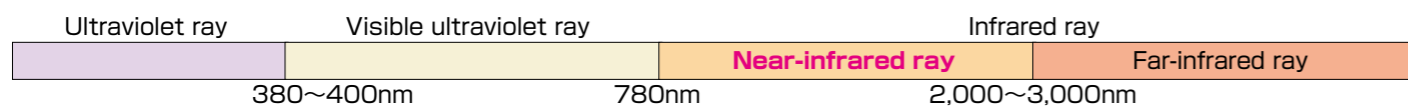

Graph1: Dispersed ray transmittance curve

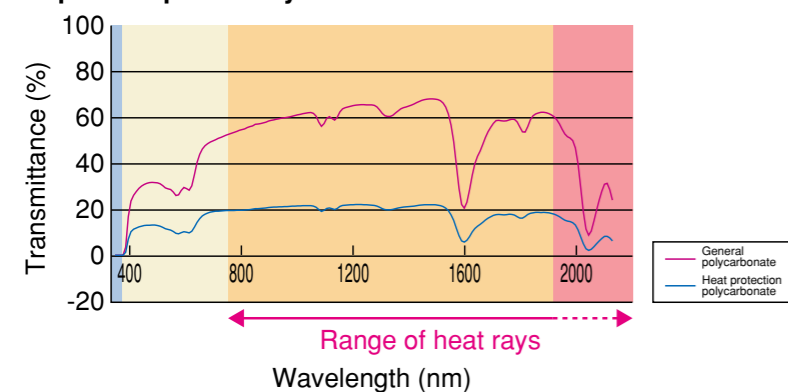

The sun's rays are classified into ultraviolet rays, visible ultraviolet rays, infrared rays etc. as shown in the wavelength in Fig. 1.

Near-infrared rays called heat rays, equivalent to about half of the entire solar radiation energy from sun beams, can cause damage to objects.

Heat protection polycarbonate sheet finished with a special mixture can restrict the sun's rays in this range more effectively compared with general polycarbonate sheet (See graph).

With this function, the solar radiation energy can be drastically reduced.

The left values are actual values measured by us and not guaranteed values products.

Model	KCR	KDR	KS/KSS	MLC Standard & Deluxe	KRB/KRBS	RSC	KWC	CSS
Polycarbonate	Cut out UV rays 100% and has a strong impact resistance 250 times higher than glass. Since it does not harden at low temperatures, it is suitable for use in cold climates.							
BR brown smoke	●	●		●	●			
AO blue smoke	●	●	●	●	●			●
SI clear mat	●	●		●		●	●	●
Heat protection polycarbonate	When looking panel from the sun side, the surface reflects sunlight. Therefore the panel color looks different from the ground side.							
AO blue smoke	●	●	●	●	●	●	●	●
Heat absorb polycarbonate	The embossed surface is diffusing sunlight and gentle light under the roof. (40% heat rays cut)							
SI clear mat			●					
Heat protection FRP	Having same features and specification of FRP panel and reducing heat ray.							
SI clear mat	●			●		●		●
Heat protection FRP DR-type	Having same features and specification of FRP panel and much more stronger & incombustibility material.							
SI clear mat				●		●	●	●
Aluminium/resin composite panel	The multiple layered composite panel which is higher advantage for fire & impact resistance.							
AI ivory white					●			

KCR  
KDR  
KS/KSS  
MLC Standard & Deluxe  
KRB/KRBS  
RSC  
KWC  
CSS